



### Main

Range of product	Harmony K
Product or component type	Complete cam switch
Component name	K1
[Ith] conventional free air thermal current	12 A
Mounting location	Front
Fixing mode	Multifixing
Cam switch head type	With front plate 45 x 45 mm
Type of operator	Black handle, length = 35 mm
Rotary handle padlocking	Without
Presentation of legend	With metallic legend, 0 - L1N - L2N - L3N - L1L2 - L2L3 - L3L1 black marking
Cam switch function	Voltmeter switch
Return	Without
Type of measurement	Between 3 phases and between each of the 3 phases and neutral
Off position	With Off position
Switching positions	Left: 0° - 315° - 270° - 225° Right: 0° - 45° - 90° - 135°
IP degree of protection	IP40 conforming to IEC 529 IP40 conforming to NF C 20-010

### Complementary

Switching angle	45 °
[Ui] rated insulation voltage	690 V (pollution degree 3) conforming to IEC 60947-1
[Ithe] conventional enclosed thermal current	10 A
Rated operational power in W	10500 W AC-21, 500...660 V 3 phases conforming to IEC 947-3 1100 W AC-3, 230 V 3 phases conforming to IEC 947-3 1500 W AC-23A, 230 V 3 phases conforming to IEC 947-3

	1500 W AC-3, 400 V 1 phase conforming to IEC 947-3 1500 W AC-3, 400 V 3 phases conforming to IEC 947-3 1500 W AC-3, 500 V 3 phases conforming to IEC 947-3 1500 W AC-3, 690 V 3 phases conforming to IEC 947-3 2200 W AC-23A, 400 V 3 phases conforming to IEC 947-3 2200 W AC-23A, 500 V 3 phases conforming to IEC 947-3 2200 W AC-23A, 690 V 3 phases conforming to IEC 947-3 4800 W AC-21, 230 V 3 phases conforming to IEC 947-3 600 W AC-3, 230 V 1 phase conforming to IEC 947-3 8300 W AC-21, 400 V 3 phases conforming to IEC 947-3
[I <sub>e</sub> ] rated operational current AC	1.8 A at 690 V AC-3 3 phases conforming to IEC 947-3 2.8 A at 500 V AC-3 3 phases conforming to IEC 947-3 2.8 A at 690 V AC-23A 3 phases conforming to IEC 947-3 3.3 A at 400 V AC-3 3 phases conforming to IEC 947-3 3.8 A at 500 V AC-23A 3 phases conforming to IEC 947-3 4.6 A at 230 V AC-3 3 phases conforming to IEC 947-3 4.8 A at 400 V AC-23A 3 phases conforming to IEC 947-3 5.6 A at 230 V AC-23A 3 phases conforming to IEC 947-3 1 A at 500 V AC-15 conforming to IEC 947-5-1 2 A at 400 V AC-15 conforming to IEC 947-5-1 3 A at 230 V AC-15 conforming to IEC 947-5-1
Electrical durability	1000000 cycles AC-15 1000000 cycles AC-21 500000 cycles AC-23 500000 cycles AC-3
Maximum operating rate	2.5 cyc/mn AC-21 2.5 cyc/mn AC-23 2.5 cyc/mn AC-3 8.333 cyc/mn AC-15
Short-circuit current	10000 A
Short-circuit protection	16 A cartridge fuse, type gG
[U <sub>imp</sub> ] rated impulse withstand voltage	4 kV in isolating function 6 kV conforming to IEC 947-1
Contact operation	Slow-break
Positive opening	With
Electrical connection	Captive screw clamp terminals flexible, clamping capacity: 2 x 1.5 mm <sup>2</sup> Captive screw clamp terminals solid, clamping capacity: 1 x 2.5 mm <sup>2</sup>
Mechanical durability	1000000 cycles
CAD overall width	45 mm
CAD overall height	45 mm
CAD overall depth	97 mm
Net weight	0.17 kg

## Environment

Standards	EN 60947-3 for power circuit EN 60947-5-1 for control circuit IEC 60947-3 for power circuit IEC 60947-5-1 for control circuit CENELEC EN 50013
Product certifications	CSA 240 V 1 hp 1 phase CSA 240 V 3 hp 3 phases 2 -pole(s) UL 240 V 1 hp 3 phases UL 240 V 0.33 hp 1 phase 2 -pole(s)
Protective treatment	TC
Ambient air temperature for operation	-25...55 °C
Ambient air temperature for storage	-40...70 °C
Shock resistance	30 gn conforming to IEC 68-2-27
Vibration resistance	5 gn conforming to IEC 68-2-6 (f = 10...150 Hz)
Overvoltage category	Class II conforming to IEC 536 Class II conforming to NF C 20-030

## Packing Units

Unit Type of Package 1	PCE
------------------------	-----

Number of Units in Package 1	1
Package 1 Weight	179 g
Package 1 Height	6.7 cm
Package 1 width	6.7 cm
Package 1 Length	11 cm
Unit Type of Package 2	S03
Number of Units in Package 2	40
Package 2 Weight	7.563 kg
Package 2 Height	30 cm
Package 2 width	30 cm
Package 2 Length	40 cm
Unit Type of Package 3	P06
Number of Units in Package 3	320
Package 3 Weight	71.804 kg
Package 3 Height	80 cm
Package 3 width	80 cm
Package 3 Length	60 cm

### Offer Sustainability

Sustainable offer status	Green Premium product
RECh Regulation	<a href="#">RECh Declaration</a>
RECh free of SVHC	Yes
EU RoHS Directive	Pro-active compliance (Product out of EU RoHS legal scope) <a href="#">EU RoHS Declaration</a>
Toxic heavy metal free	Yes
Mercury free	Yes
RoHS exemption information	<a href="#">Yes</a>
China RoHS Regulation	<a href="#">China RoHS declaration</a>
Environmental Disclosure	<a href="#">Product Environmental Profile</a>
WEEE	The product must be disposed on European Union markets following specific waste collection and never end up in rubbish bins

### Contractual warranty

Warranty	18 months
----------	-----------

---

Operating Head and Body

---

Front Mounting "Multi-Fixing"

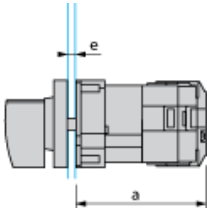

- a 73 mm/2.87 in.
- e support panel thickness 1 mm to 6 mm./0.039 in. to 0.24 in.

---

Link Positions (Factory Mounted)

---

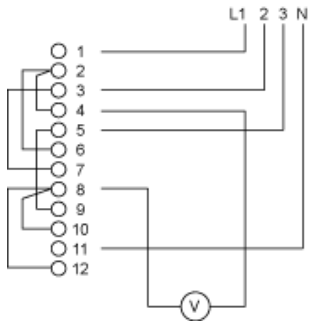

---

Marking

---



---

Angular Position of Switch

---



Switching Program

225	270	315	0	45	90	135	
X		X		X			1
	X				X		2
						X	3
							4
							5
		X					6
							7
X	X						8
							9
				X		X	10
							11
							12



---

### Convention Used for Switching Program Representation

---

Contact closed

Contact closed in 2 positions and maintained between the 2 positions

Sealed assembly for auto-maintain control

Overlapping contacts

Spring return position: for a switching angle of  $90^\circ$ , spring return is over  $30^\circ$  after the last position (for a maximum of 3 simultaneous contacts).

Example:

